



Texture One Zero Model Based on A_4 Flavor Symmetry and its Implications to Neutrinoless Double Beta Decay

Rishu Verma , Monal Kashav , Ankush , Gazal Sharma , Surender Verma  and B. C. Chauhan 

Department of Physics and Astronomical Science, Central University of Himachal Pradesh, Dharamshala, Himachal Pradesh - 176215, India

*bcawake@hpcu.ac.in (Corresponding Author)

ARTICLE INFORMATION

Received: January 19, 2021
Accepted: April 19, 2021
Published Online: August 31, 2021

Keywords:

Inverse seesaw, Neutrinoless double beta decay, A_4 flavor group, Texture one zero



DOI: 10.15415/jnp.2021.91012

ABSTRACT

Neutrinos are perhaps the most elusive particles in our Universe. Neutrino physics could be counted as a benchmark for various new theories in elementary particle physics and also for the better understanding of the evolution of the Universe. To complete the neutrino picture, the missing information whether it is about their mass or their nature that the neutrinos are Majorana particles could be provided by the observation of a process called neutrinoless double beta ($0\nu\beta\beta$) decay. Neutrinoless double beta decay is a hypothesised nuclear process in which two neutrons simultaneously decay into protons with no neutrino emission. In this paper we proposed a neutrino mass model based on A_4 symmetry group and studied its implications to $0\nu\beta\beta$ decay. We obtained a lower limit on $|M_{ee}|$ for inverted hierarchy and which can be probed in $0\nu\beta\beta$ experiments like SuperNEMO and KamLAND-Zen.

1. Introduction

Our knowledge about the fundamental laws of Universe has been greatly enriched by the efforts made in the various experimental and theoretical fields of physics, but at the same time many new mysteries about the working of the universe have confronted us. The most intriguing one is the existence of the elusive elementary particle i.e., 'neutrino'. The remarkable history of the neutrino begins with the investigation of the β -decay. To recover the energy conservation of the β -decay, lead to theoretical formulation of this new particle in 1930 by Pauli. Due to extremely small cross section, detection of neutrinos is comparatively much more difficult than for other standard model particles, and needs some special techniques to detect them. Neutrinos interacts with matter via the exchange of the heavy virtual W^\pm and Z -bosons. Since the discovery of neutrinos many new phenomenon and various Standard Model(SM) came into existence. But the establishment of the concept of neutrino oscillations which clearly indicated the existence of neutrino mass, $0\nu\beta\beta$ decay came into a bigger picture. Since the existence of the $0\nu\beta\beta$ decay is related to the neutrino mass, the $0\nu\beta\beta$ decay gained increasing importance with the discoveries made by the various oscillation experiments. The first signature of a physics beyond the SM was obtained in the

neutrino oscillation experiments which hinted towards the new mechanism required for the neutrino mass generation. The smallness of the neutrino mass could be explained by assuming that the total lepton number is violated at some high energy scale (10^{15} - 10^{16} GeV). The leptons and quarks are Dirac particles. The leptons (antileptons) as well as the quarks (antiquarks) are different particles, they have the same masses but their electric charges are different. If neutrinos are Majorana particles, in this case neutrinos and antineutrinos are identical. Observation of the $0\nu\beta\beta$ would be a definite validation that neutrinos are the Majorana particle.

In this paper we have used Inverse seesaw mechanism [1-3] to generate right-handed neutrino masses at TeVscale. Using A_4 flavor symmetry, we proposed a model in which we implemented type-II seesaw mechanism [4] to reduce the number of parameters in neutrino mass matrix. We also used Z_2 and Z_3 symmetries to avoid extra terms in our lagrangian.

This paper is structured as follows. In section 2, we discussed about inverse seesaw mechanism. In section 3, we discussed A_4 symmetry group and our model. The section 4 is devoted to neutrinoless double beta decay. Finally, conclusions are summarized in section 5.

2. Inverse Seesaw Mechanism

Inverse seesaw is an important mechanism to generate small neutrino mass. Inverse Seesaw is able to generate neutrino mass near TeV scale [1]. In this mechanism three extra right-handed neutrinos N_T ($T=1,2,3$) and three singlet fermions S_T ($T=1,2,3$) are required to be added, resulting the lagrangians shown below

$$L = \bar{\nu}_L m_D N - \bar{S}_L m N - \frac{1}{2} \bar{S}_L \mu S_L^C + h.c., \quad (1)$$

where ' m_D ', ' m ' and ' μ ' are the 3×3 complex mass matrices. Here ' m ' represents the interaction between neutral fermions and right-handed neutrinos. The ' μ ' gives the Majorana mass terms for singlet fermions. The corresponding neutrino mass matrix have the form

$$M_\nu = \begin{pmatrix} 0 & m_D & 0 \\ m_D^T & 0 & m \\ 0 & m^T & \mu \end{pmatrix}. \quad (2)$$

If we consider the order $\mu \ll m_D \ll m$, then after the block diagonalization of above matrix, the 3×3 effective neutrino mass matrix is obtained as

$$m_\nu = m_D (m^T)^{-1} \mu m^{-1} m_D^T. \quad (3)$$

where ' m^T ' and ' M_D^T ' are the transpose of mass matrices ' m ' and ' m_D ', respectively

3. The Model

Non-abelian discrete symmetry group A_4 is a group of even permutations of four objects. The order of group A_4 is 12. Two elements of this group i.e.,

$$S = \begin{pmatrix} 1 & 0 & 0 \\ 0 & -1 & 0 \\ 0 & 0 & -1 \end{pmatrix} \text{ and } T = \begin{pmatrix} 0 & 0 & 1 \\ 1 & 0 & 0 \\ 0 & 1 & 0 \end{pmatrix},$$

generate all the 12 elements of group, and satisfies: $S^2 = T^3 = (ST)^3$. The geometrical representation of group A_4 is of regular tetrahedron. The elements S and T corresponds to reflection and rotation, respectively. The group has four conjugacy classes, so it has four irreducible representations, three singlets i.e., $1-1'-1''$ and one triplet, 3 [5].

The model is an extension of the Standard Model by five right-handed neutrinos, N_T ($T = 1,2,3$), N_4 and N_5 and five fermion singlets, S_T ($T=1,2,3$), S_4 and S_5 . The fermion field content and respective charge assignments are shown in "Table 1" and scalar field content and respective charge assignments are shown in "Table 2".

Table 1: Fermion fields used in the model and their respective charge assignments.

Symmetry	L_e	L_μ	L_τ	l_e^c	l_μ^c	l_τ^c	N_T	N_4	N_5	S_T	S_4	S_5
$SU(2)_L$	2	2	2	1	1	1	1	1	1	1	1	1
A_4	1	1'	1''	1	1''	1'	3	1	1'	3	1	1'
Z_2	1	1	1	1	1	1	1	1	1	-1	-1	-1
Z_3	ω	ω	ω	ω^2	ω^2	ω^2	ω^2	ω^2	ω^2	ω	ω	ω

Table 2: Scalar fields used in the model and their respective charge assignments.

Symmetry	H	η	ϕ	ϕ_R	ϕ_S	Δ_1	Δ_2
$SU(2)_L$	2	2	1	1	1	3	3
A_4	1	3	3	1	1	1	1'
Z_2	1	1	-1	-1	1	1	1
Z_3	1	1	1	1	ω	ω	ω

We implemented the Z_2 and Z_3 cyclic symmetries along with A_4 symmetry in order to constrain the extra couplings in the lagrangian. The leading Yukawa Lagrangian of the model obtained using inverse seesaw is

$$\begin{aligned} L_{ISS} = & y_e L_e l_e^c H + y_\mu L_\mu l_\mu^c H + y_\tau L_\tau l_\tau^c H \\ & + y_\nu^1 L_e N_T \eta + y_\nu^2 L_\mu N_T \eta + y_\nu^3 L_\tau N_T \eta \\ & + y_\nu^4 L_e N_4 H + y_\nu^5 L_\tau N_5 H + y_R^0 N_4 S_4 \phi_R \\ & + y_R^1 N_T S_T \phi_R + y_\phi^1 N_T S_4 \phi + y_\phi^2 N_T S_5 \phi \\ & + y_\phi^3 N_T S_T \phi + y_s^1 S_T S_T \phi_s + y_s^2 S_4 S_4 \phi_s + h.c., \end{aligned} \quad (4)$$

In addition to Higgs field H , we have used η , ϕ , ϕ_R , ϕ_S , fields in the model and their respective charge assignments are shown in "Table 2". In "Eq. 4", $y_e, y_\mu, y_\tau, y_\nu^1, y_\nu^2, y_\nu^3, y_\nu^4, y_\nu^5, y_R^0, y_R^1, y_\phi^1, y_\phi^2, y_\phi^3, y_s^1, y_s^2$ are the Yukawa couplings. The type-II seesaw contribution to the Lagrangian is

$$\begin{aligned} L_{type-II} = & f_1 (L_e L_e + L_\mu L_\tau + L_\tau L_\mu) \Delta_1 \\ & + f_2 (L_e L_\tau + L_\tau L_e + L_\mu L_\mu) \Delta_2 + h.c. \end{aligned} \quad (5)$$

After applying the vacuum expectation values i.e., $\langle \eta \rangle \sim v_\eta (1,0,0)$, $\langle \phi \rangle \sim v_\phi (1,0,0)$, $\langle H \rangle = v_h$, $\langle \phi_R \rangle = v_R$, $\langle \phi_S \rangle = v_S$, $\langle \Delta_1 \rangle = v_{\Delta_1}$, $\langle \Delta_2 \rangle = v_{\Delta_2}$, we obtained a charged leptonic mass matrix as $m_l = \text{Diag}(y_e, y_\mu, y_\tau) v_h$. Other mass matrices are obtained as,

$$\begin{aligned} m_D = & \begin{pmatrix} A & 0 & 0 & F & 0 \\ B & 0 & 0 & 0 & 0 \\ C & 0 & 0 & 0 & H \end{pmatrix}, \\ m = & \begin{pmatrix} x & 0 & 0 & l & v \\ 0 & x & h & 0 & 0 \\ 0 & h & x & 0 & 0 \\ l & 0 & 0 & z & 0 \\ v & 0 & 0 & 0 & 0 \end{pmatrix} \text{ and } \mu = \begin{pmatrix} y & 0 & 0 & 0 & 0 \\ 0 & y & 0 & 0 & 0 \\ 0 & 0 & y & 0 & 0 \\ 0 & 0 & 0 & n & 0 \\ 0 & 0 & 0 & 0 & 0 \end{pmatrix}. \end{aligned}$$

where, $A = y_v^1 v_n, B = y_v^2 v_n, C = y_v^3 v_n, F = y_v^4 v_h, H = y_v^5 v_h,$
 $y = y_s^1 v_s, n = y_s^2 v_s, x = y_R^1 v_R, z = y_R^0 v_R, l = y_\phi^1 v_\phi, v = y_\phi^2 v_\phi,$
 $h = y_\phi^3 v_\phi.$ Under inverse seesaw + type-II mechanism, the above matrices lead to the light neutrino mass matrix as follow

$$M_\nu = \begin{pmatrix} X + X' & 0 & \Delta + \Delta' \\ 0 & \Delta' & X' \\ \Delta + \Delta' & X' & \Delta'' \end{pmatrix}, \quad (5)$$

where,
 $X = F^2 n / z^2, X' = f_1 v \Delta_1, \Delta = -FH \ln / v z^2, \Delta' = f_2 v \Delta_2,$
 $\Delta'' = H^2 (l^2 n + y z^2) / v^2 z^2.$ The neutrino mass matrix obtained is a texture one zero mass matrix as it contains one element equal to zero. Since the neutrino mass matrix is symmetric, so $(M\nu)_{12} = (M\nu)_{21},$ and is counted as one element. Texture zero models are widely used in literature to reduce the number of parameters in neutrino mass matrix.

4. Neutrinoless Double Beta Decay ($0\nu\beta\beta$)

In order to reveal the nature of neutrinos with definite masses, it is necessary to study processes in which the total lepton number L is violated. At present it seems that the only feasible experiment to settle whether neutrinos are Majorana neutrinos is neutrinoless double beta decay. Neutrinoless Double Beta Decay is a hypothesised nuclear process in which two neutrons simultaneously decay into protons with no neutrino emission. The $0\nu\beta\beta$ -decay is presently the only feasible way to establish the Majorana nature of neutrinos which would imply that neutrinos are their own anti-particles. Neutrino-less double beta decay is represented by

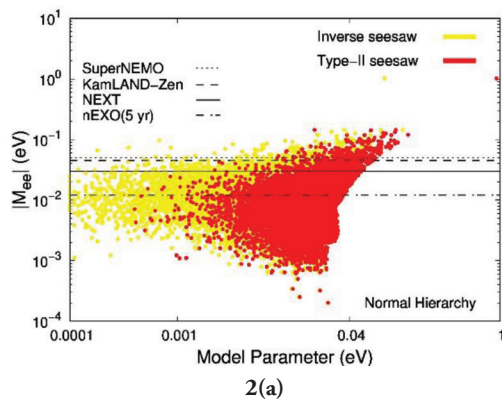
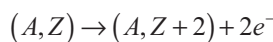

The Feynman diagram for $0\nu\beta\beta$ -decay is shown in Fig. 1. In this process, only two electrons are emitted. This is possible if and only if the neutrinos are Majorana particles.

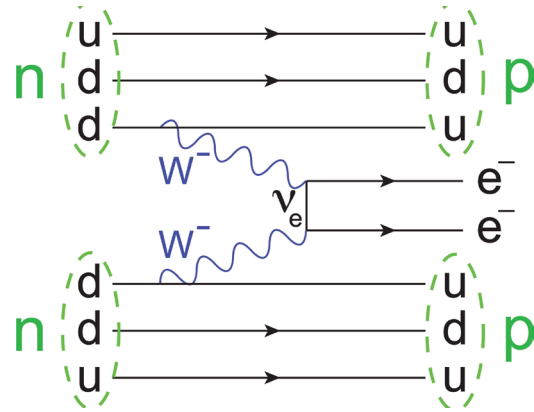

Figure 1: Feynman diagram for neutrino-less double beta decay.

We obtained texture one zero neutrino mass matrix as shown in Eq. (5). There are a number of neutrino mass models, but texture zero models are very successful as they have high predictability and rich phenomenology [6-15]. This kind of one zero mass matrix is T_2 texture [15]. This type of texture one zero mass matrix has non zero contribution towards $0\nu\beta\beta$ -decay and we used similar methodology to study its implications to $0\nu\beta\beta$ -decay as in Ref. [15].

It is clear from Eq. (4) that we can distinguish the contribution of inverse seesaw and type-II seesaw to $|M_{ee}|,$ as $|M_{11}|$ element of the mass matrix is sum of both seesaw mechanisms. We have plotted the model parameters X (inverse seesaw contribution) and X' (type-II seesaw contribution) with effective Majorana neutrino mass $|M_{ee}|.$ We have also shown the sensitivity reach of $0\nu\beta\beta$ -decay of experiments like SuperNEMO [16], NEXT [17, 18], KamLAND-Zen [19], and nEXO [20] in our plots shown in Fig. (2) below.

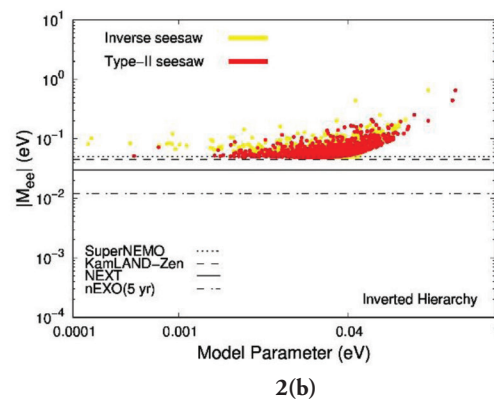
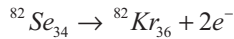

Figure 2: Variation of $|M_{ee}|$ with model parameters X (ISS contribution) and X' (type-II contribution) for normal hierarchy and inverted hierarchy.

The main isotope used in SuperNEMO is ^{82}Se , and it decays as



For NEXT, KamLAND-Zen and nEXO experiments, the main isotope used is ^{136}Xe and the decay is shown as



For numerical analysis, we used neutrino oscillations experimental data NuFIT 5.0 [21]. It is clear from Fig. 2(a), for inverted hierarchy scenario, we did not get any clear lower bound for $|M_{ee}|$. In case of normal hierarchy, we obtained a clear lower bound as can be seen in Fig. 2(b), and it is in the sensitivity range of the SuperNemo and KamLAND-Zen experiments.

Conclusions

Neutrinos are massless in SM as there is no right-handed neutrino present in this model. According to the SM, neutrinos are electrically neutral and massless particles with three active flavors (ν_e, ν_μ, ν_τ). The mystery of the nature of neutrinos (Dirac or Majorana) is one of the most fundamental problem of neutrino physics. The solution of this problem will have an important impact on the understanding of the origin of neutrino masses and mixing. The evolution of neutrino oscillations gave a new direction towards non-zero neutrino mass, but it did not give any hint about the nature of neutrinos with definitemass. Hence in order to give mass to neutrinos we need some kind of new physics.

We have extended the SM by using $A_4 \times Z_2 \times Z_3$ flavor symmetry. A clear lower bound for $|M_{ee}|$ is found for inverted hierarchy case which is in the sensitivity range of the $0\nu\beta\beta$ -decay experiments like KamLAND-Zen and SuperNEMO, hence can be examined in these experiments.

Acknowledgement

One of the authors B.C. Chauhan is thankful to the Inter University Centre for Astronomy and Astrophysics (IUCAA) for providing necessary facilities during this work. Another author Monal Kashav acknowledges the financial support provided by Department of Science and Technology, Government of India under DST-INSPIRE fellowship program (IF180327).

References

- [1] R. N. Mohapatra, Phys. Rev. Lett. **56**, 561 (1986). <https://doi.org/10.1103/PhysRevLett.56.561>
- [2] M. C. Gonzalez-Garcia and J. W. Walle, Phys. Lett. B **216**, 360 (1989). [https://doi.org/10.1016/0370-2693\(89\)91131-3](https://doi.org/10.1016/0370-2693(89)91131-3)
- [3] F. Deppisch and J. W. F. Walle, Phys. Rev. D **72**, 036001 (2005). <https://doi.org/10.1103/PhysRevD.72.036001>
- [4] M. Magg and C. Wetterich, Phys. Lett. B **94**, 61 (1980). [https://doi.org/10.1016/0370-2693\(80\)90825-4](https://doi.org/10.1016/0370-2693(80)90825-4)
- [5] H. Ishimori, T. Kobayashi, H. Ohki, H. Okada, Y. Shimizu and M. Tanimoto, Prog. Theor. Phys. Suppl. **183**, 1 (2010). <https://doi.org/10.1143/PTPS.183.1>
- [6] P. H. Frampton, S. L. Glashow and D. Marfatia, Phys. Lett. B **536**, 79 (2002). [https://doi.org/10.1016/S0370-2693\(02\)01817-8](https://doi.org/10.1016/S0370-2693(02)01817-8)
- [7] Z. -Z. Xing, Phys. Lett. B **530**, 159 (2002). [https://doi.org/10.1016/S0370-2693\(02\)01354-0](https://doi.org/10.1016/S0370-2693(02)01354-0)
- [8] W. Guo and Z. -Z. Xing, Phys. Rev. D **67**, 053002 (2003). <https://doi.org/10.1103/PhysRevD.67.053002>
- [9] S. Dev and S. Kumar, Mod. Phys. Lett. A **22**, 1401 (2007). <https://doi.org/10.1142/S0217732307021767>
- [10] S. Dev, S. Kumar, S. Verma and S. Gupta, Phys. Rev. D **76**, 013002 (2007). <https://doi.org/10.1103/PhysRevD.76.013002>
- [11] S. Dev, S. Verma, S. Gupta and R. R. Gautam, Phys. Rev. D **81**, 053010 (2010). <https://doi.org/10.1103/PhysRevD.81.053010>
- [12] S. Verma, Adv. High Energy Phys. **2015**, 385968 (2015). <https://doi.org/10.1155/2015/385968>
- [13] S. Dev, S. Kumar and S. Verma, Mod. Phys. Lett. A **24**, 2251 (2009). <https://doi.org/10.1142/S0217732309030680>
- [14] S. Verma, M. Kashav and S. Bhardwaj, Nucl. Phys. B **946**, 114704 (2019). <https://doi.org/10.1016/j.nuclphysb.2019.114704>
- [15] S. Verma and M. Kashav, Mod. Phys. Lett. A **35**, 2050165 (2020). <https://doi.org/10.1142/S0217732320501655>
- [16] A. S. Barabash, J. Phys. Conf. Ser. **375**, 042012 (2012). <https://doi.org/10.1088/1742-6596/375/1/042012>
- [17] F. Granena et al., arXiv:0907.4054[hep-ex].
- [18] J. J. Gomez-Cadenas et al., Adv. High Energy Phys. **2014**, 907067 (2014). <https://doi.org/10.1155/2014/907067>
- [19] A. Gando et al., Phys. Rev. Lett. **117**, 082503 (2016). <https://doi.org/10.1103/PhysRevLett.117.082503>
- [20] C. Licciardi, J. Phys. Conf. Ser. **888**, 012237 (2017). <https://doi.org/10.1088/1742-6596/888/1/012237>
- [21] I. Esteban, M. Gonzalez-Garcia, M. Maltoni, et al. J. High Energ. Phys. **2020**, 178 (2020). [https://doi.org/10.1007/JHEP09\(2020\)178](https://doi.org/10.1007/JHEP09(2020)178).



Journal of Nuclear Physics, Material Sciences, Radiation and Applications

Chitkara University, Saraswati Kendra, SCO 160-161, Sector 9-C,
Chandigarh, 160009, India

Volume 9, Issue 1

August 2021

ISSN 2321-8649

Copyright: [© 2021 Rishu Verma et al.] This is an Open Access article published in Journal of Nuclear Physics, Material Sciences, Radiation and Applications (J. Nucl. Phys. Mat. Sci. Rad. A.) by Chitkara University Publications. It is published with a Creative Commons Attribution- CC-BY 4.0 International License. This license permits unrestricted use, distribution, and reproduction in any medium, provided the original author and source are credited.